

Featuring a large through-hole, a servo motor, and a smart controller, PT-200P welding positioner simplifies welding procedure and enhance performance.

### Features

- Servo Motor : Equipped with high-precision servo motors, offering stable speed control, enhancing welding quality and efficiency
- Smart control system : A user interface designed specifically for welding operations
- Full automation compatibility : Works seamlessly with a wide range of automation accessories



• PT-200P-100

### Specification

Model	Unit	PT-200P-62	PT-200P-100
Power input		1Ø 220VAC 50/60Hz	
Capacity	kg	200	
Table dimension	mm	Ø300	
Rotation speed	rpm	0.02 ~ 30	
Through hole diameter	mm	Ø62	Ø100
Earthing	amp	300	
Tilt range	deg	0 ~ 90	
Dimension (A x B x C)	mm	465 x 315 x 365	
Center to floor (D)	mm	250	
Weight	kg	43	45

※ Specifications subject to change.

### Dimensions

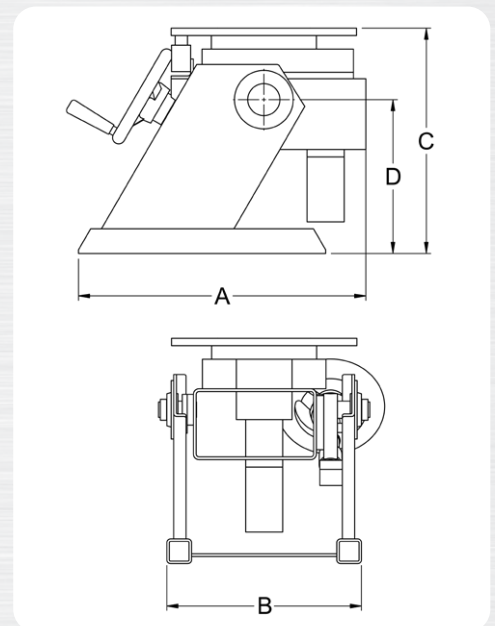

### Options

- PG-300L 3-Jaw chuck  
Self-centering, fast clamping and quick release  
OD : 50 ~ 300 mm



• P/N : 0147-0010